



INCLUDED



802.3at



802.3af/at



IP67



2



The NetWave® industrially hardened wireless dual radio Ethernet transmission device is designed to be used with an external antenna and is used for **redundant ring and drop & repeat topologies**. Both radios can be configured through the embedded User Interface as a Client or as an Access Point. Radio 2 supports 5GHz operation and is connected to the 19dBi internal antenna. Radio 1 is user selectable for 5GHz or 2.4GHz and connects to an external antenna. The NW8 and NW8E support up to 145Mbps throughput using MIMO technology. The units can be powered by an IEEE 802.3af/at PoE compliant device or through a supplied power injection module with the second Ethernet port operational as an IEEE802.3at PoE power source. The NW8 is FCC certified for use in North America and the NW8E is ETSI, DFS and TPC certified for use in the European Union.

## FEATURES

- › Lifetime Warranty
- › IEEE802.3at PoE Compliant PD and PSE
- › Over current protection and 3 layers of Ethernet surge suppression on the PD port
- › 802.11a/n Compliant
- › Distances up to 2 mi (FCC) or 2km (ETSI)
- › Environmentally Hardened -40° to +70°C
- › Meets class IP67 dust and water immersion protection standards
- › ETSI Standards (EU Region only):
  - DFS Dynamic Frequency Selection
  - TPC Transmit Power Control
- › Secure transmission: WPA2 - AES or TKIP encryption
- › ComNet Antenna alignment feature eases installation and setup
- › RF Spectrum Survey Tools
- › Antenna Alignment Tools
- › LED array displays unit operational status along with received signal strength

## APPLICATIONS

- › Installations that require redundant ring or linear drop and repeat topologies
- › Ideal for PoE Camera connectivity
- › Installations that require connecting to more than one Ethernet device
- › Simple to deploy and cost-effective alternative to physical connections to Ethernet edge equipment
- › Integration of Ethernet where right-of-way issues mandate wireless communications
- › ITS traffic signalization networks and Video Detection Systems (VDS)
- › ITS roadside and city center CCTV surveillance, and surveillance of high-value or mission-critical assets
- › Wireless communications in manufacturing, petrochemical refineries, wastewater treatment facilities, and other industrial automation and control applications operating in harsh or out-of-plant environments
- › Electrical substation video and perimeter surveillance

SPECIFICATIONS

2.4GHz Wireless Radio

EIRP	NW8 (FCC): +4dBm to +17dBm, or +4dBm to +26dBm with MAC-lock enabled NW8E (ETSI): +20dBm
RF Output	+23dBm Rated Transmitter
Operational Frequency	NW8: (FCC) 2412 - 2462MHz NW8E: (ETSI) 2412 - 2472MHz
Bandwidths	10, 20, 20/40MHz

5GHz Wireless Radio

EIRP	NW8 (FCC): +35dBm/+45dBm with MAC-lock enabled NW8E (ETSI): +30dBm
RF Output	+26dBm Rated Transmitter
Operational Frequency	NW8: (FCC) UNII3 5745-5825MHz NW8E: (ETSI) 5500-5700MHz supporting 802.11h ETSI DFS and TPC
Bandwidths	10, 20, and 40MHz

Internal Antenna (Connected to Radio 2)

Antenna	Internal 19dBi Dual Polarized Directional
Gain	19dBi
Azimuth	17° Horizontal/Vertical
Elevation	17° Horizontal/Vertical

Connectors

Gigabit Ethernet	2 × RJ-45, Sealed Cable Gland
External Antenna (Radio 1)	2 × N-Type 50 ohm

LEDs

Power On
Ethernet Link
Signal Strength
LAN port

Software Features

Addressing	Static IP / DHCP Client / DHCP Server
SNMP	V2c
Spanning Tree Protocol support	
Telnet Server	
Syslog	
802.1x Port-Based Network Access Control	
NTP Client	
User-Configurable Watchdog and Auto-Reboot Mechanism	
Multi-Level Configuration and Monitoring Login Accounts	
User Configurable Long Range Parameters	

Power

Operating Power	24VDC @ 200mA 48VDC @ 100mA
Power Consumption	4.8W
PD Power	IEEE802.3af/at PD compliant
PSE Power	IEEE802.3at PSE compliant

Mechanical

Size (L × W × H)	10.0 × 10.0 × 3.4 in. (25.7 × 25.7 × 8.6 cm)
Shipping Weight:	<2lbs/0.9kg

Environmental

MTBF	>100,000 hours
Operating Temp	-40° C to +70° C
Storage Temp	-40° C to +85° C
Relative Humidity	5% to 95%

NOTE: In a continuing effort to improve and advance technology, product specifications are subject to change without notice.



ORDERING INFORMATION

Part Number	Description
NW8	Individual Hardened Dual Radio, Two Gb Ethernet Ports, One internal 19dBi 17° beamwidth directional antenna, includes power injection module, power supply and mounting assembly, Port 1 Supports 802.3at PD PoE Power, Port 2 provides IEEE802.3at PSE PoE Power, FCC certified for use in NA Region
NW8E	Individual Hardened Dual Radio, Two Gb Ethernet Ports, One internal 19dBi 17° beamwidth directional antenna, includes power injection module, power supply and mounting assembly, Port 1 Supports 802.3at PD PoE Power, Port 2 provides IEEE802.3at PSE PoE Power, ETSI certified for use in EU Region
External Antenna Options	NWAVBS1 - External Dual Polarization 4.9-5.8GHz 16dBi Variable Beam Sector Antenna NWAODA1 - External Omni Directional Dual Band (2dBi@2.4GHz / 5dBi@5GHz) Antenna, N Type Connector, 45° and 90° Articulating Joint NWADA1 - External Dual Polarization 4.9-5.8GHz 19dBi 17° Beamwidth Directional Antenna
Included Accessories	Power Kit with Power Supply and Passive Power Injector Mounting Hardware Kit (For Pole Mounting Only)
Options	NWBKT - Articulating Wall or Pole Mounting Kit. Supports up to 3in/76mm diameter poles. (Sold Separately) Add /IA870 for 8dBi/70° Internal Antenna 24 VDC Recommended Power Supply (Part PS24-1A-DIN Not Included) 48 VDC Recommended Power Supply (Part PS48VDC-.84A Not Included)

TYPICAL REDUNDANT RING TOPOLOGY APPLICATION

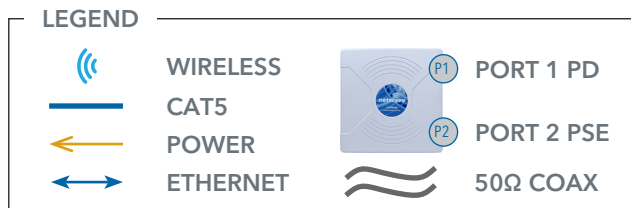
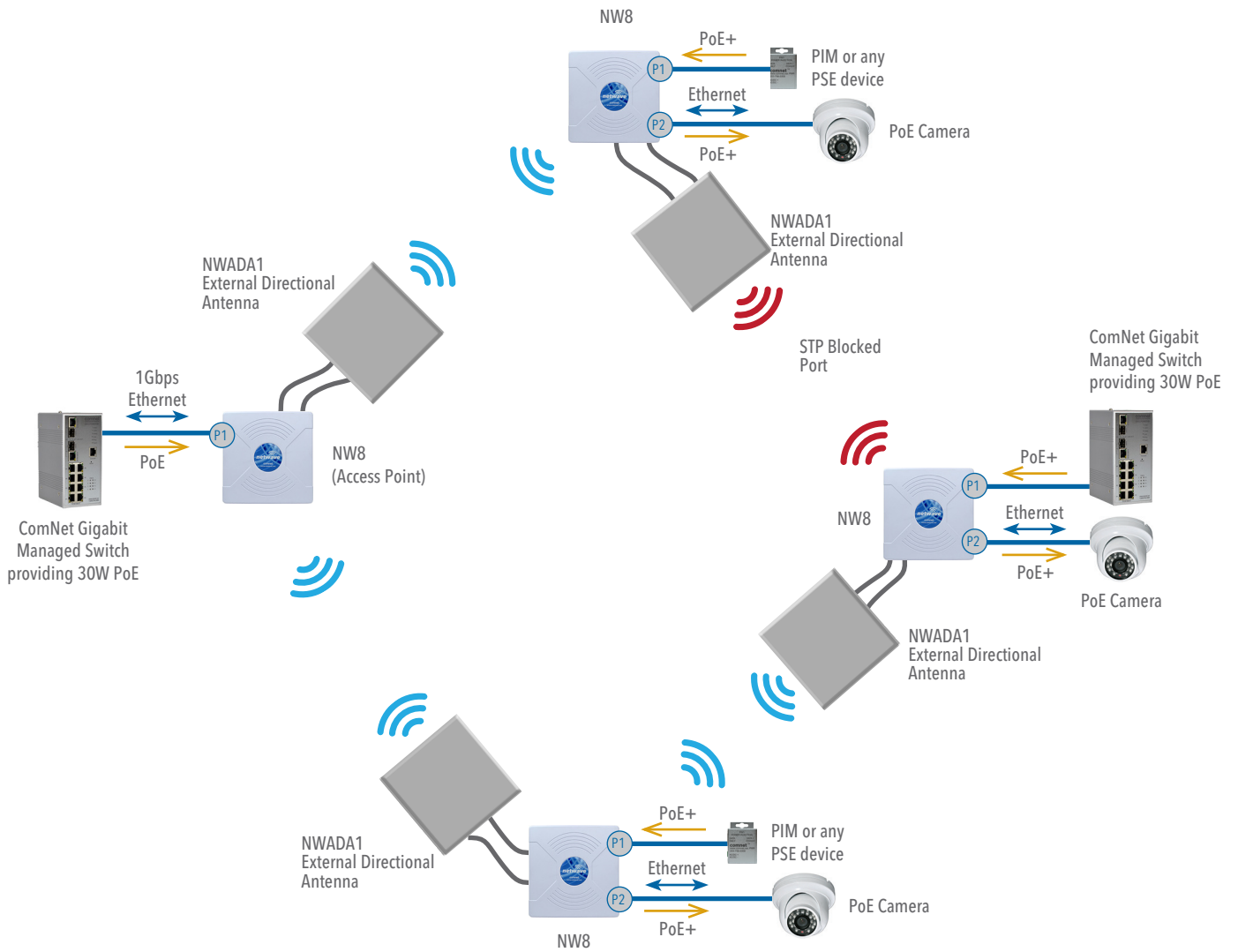

TYPICAL DROP-AND-REPEAT TOPOLOGY APPLICATION

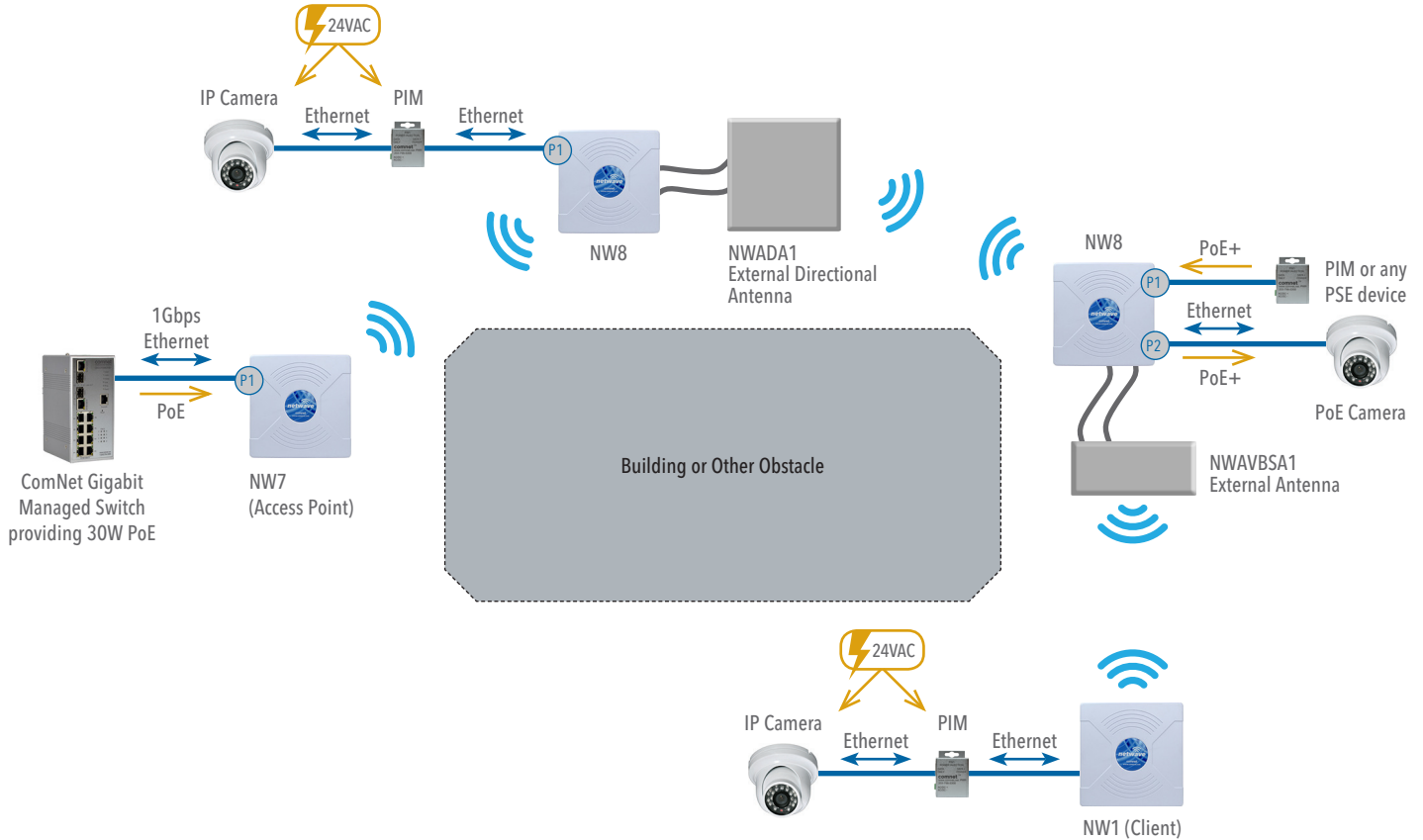

LEGEND	
	WIRELESS
	CAT5
	POWER
	ETHERNET
	PORT 1 PD
	PORT 2 PSE
	50Ω COAX